

## Charge Air Cooler

### Material

Item	Specification
Motorcraft® Premium Gold Engine Coolant with Bittering Agent (bittered in US only) VC-7-B (US); CVC-7-A (Canada); or equivalent (yellow color)	WSS-M97B51-A1
Threadlock and Sealer TA-25	WSK-M2G351-A5

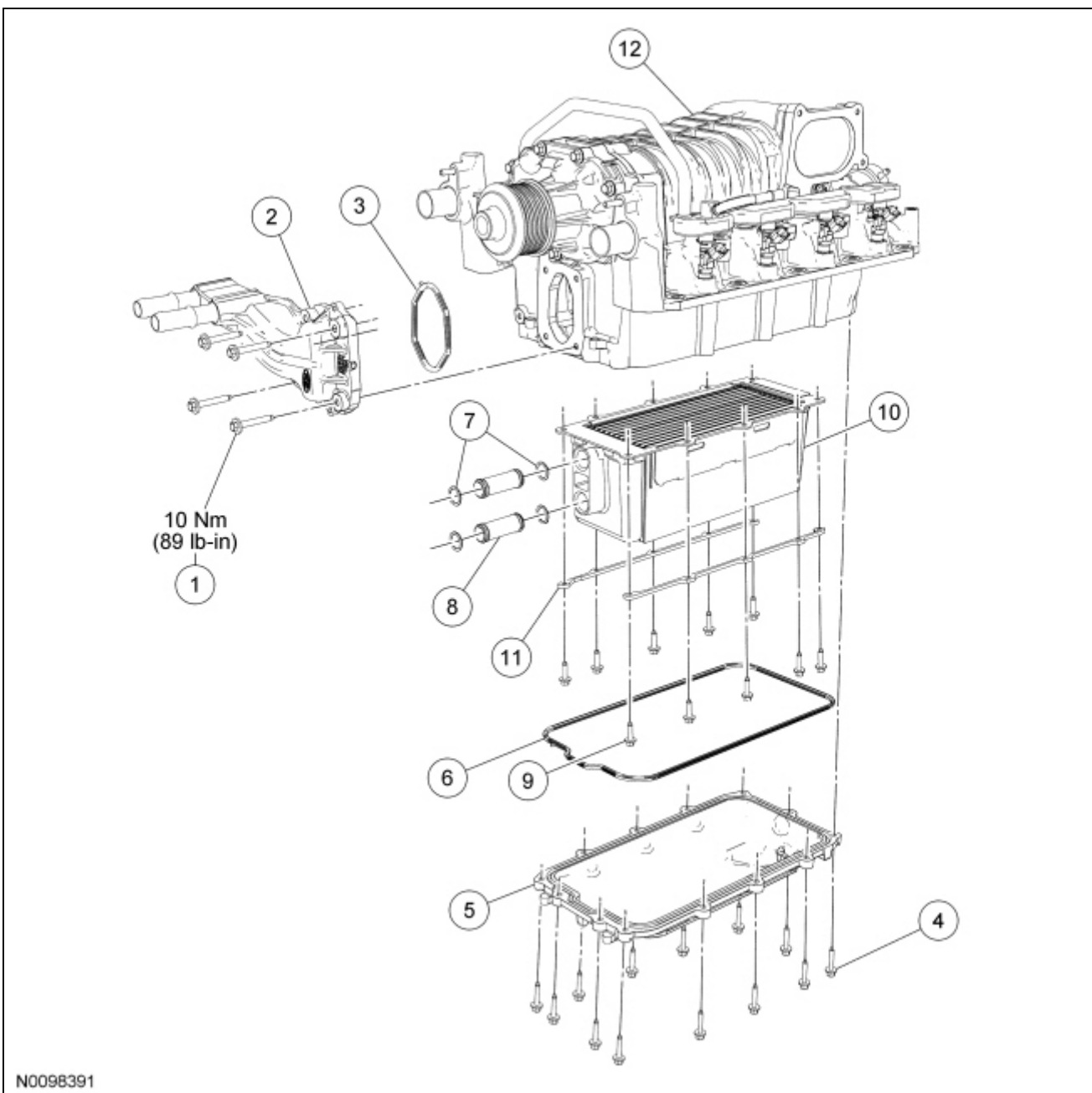

Item	Part Number	Description

1	N807071	Charge Air Cooler (CAC) coolant tube assembly bolt (4 required)
2	6F077	CAC coolant tube assembly
3	9L438	CAC coolant tube assembly gasket
4	W704682	Lower intake manifold cover bolt (13 required)
5	9K461	Lower intake manifold cover
6	9E436	Lower intake manifold cover gasket
7	N802927	CAC tube O-ring seals (4 required)
8	9L442	CAC coolant connector tube (2 required)
9	N605892	CAC bolt (10 required)
10	6K775	CAC
11	6K808	CAC rail support (2 required)
12	6F066	Supercharger (SC)

### Removal

1. Remove the intake manifold. For additional information, refer to [Section 303-01C](#).
2. Remove the 4 bolts and the Charge Air Cooler (CAC) coolant tube assembly.
3. Remove the 2 CAC coolant connector tubes and the 4 O-ring seals.
  - Discard the O-ring seals.
4. Remove the 13 bolts and the lower intake manifold cover and gasket.
5. Remove the 10 bolts, the 2 CAC rail supports and the CAC.

### Installation

1. **NOTE:** Apply threadlock and sealer to the CAC bolts prior to installation.

Position the CAC and install the support rails and bolts.

- Tighten the bolts in the sequence shown in 2 stages:
  - Stage 1: Tighten to 2 Nm (18 lb-in).
  - Stage 2: Tighten to 10 Nm (89 lb-in).

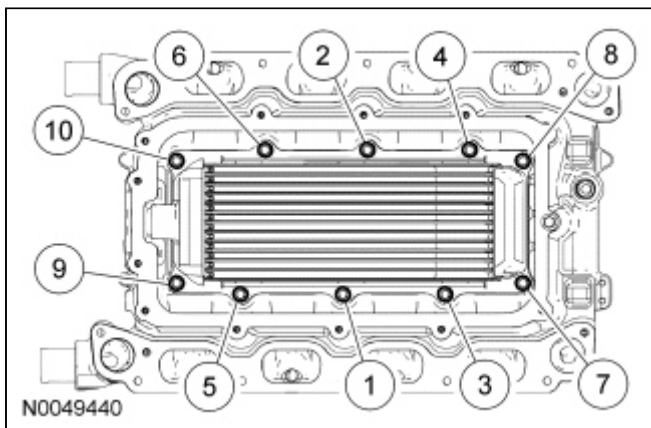

2. **NOTE:** Inspect the lower intake manifold cover gasket. Install a new gasket if necessary.

Position the gasket and the lower intake manifold cover, and install the bolts.

- Tighten the bolts in the sequence shown to 10 Nm (89 lb-in).

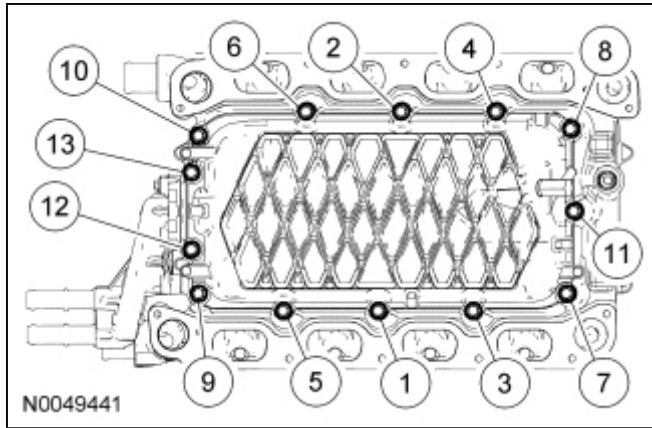

3. Apply clean engine coolant to the new [CAC](#) coolant connector tube O-ring seals, and install them on the [CAC](#) coolant connector tubes.
4. Install the [CAC](#) coolant connector tubes.
5. **NOTE:** Inspect the [CAC](#) coolant tube assembly and gasket. Install a new gasket if necessary.

Position the gasket and the [CAC](#) coolant tube assembly, and install the bolts.

- Tighten to 10 Nm (89 lb-in).

6. Install the intake manifold. For additional information, refer to [Section 303-01C](#).
-